

LEVELING CASTER 높낮이 조절용 캐스타	FOOT MASTER® GD-150	HEAVY DUTY PURPOSE 고 중하중용(高 重荷重用)
---------------------------------------	-------------------------------	---

■ Outlines (외형도)

Unit : mm (inch)



GD-150F-B
(Wheel with ball bearing)



GD-150F

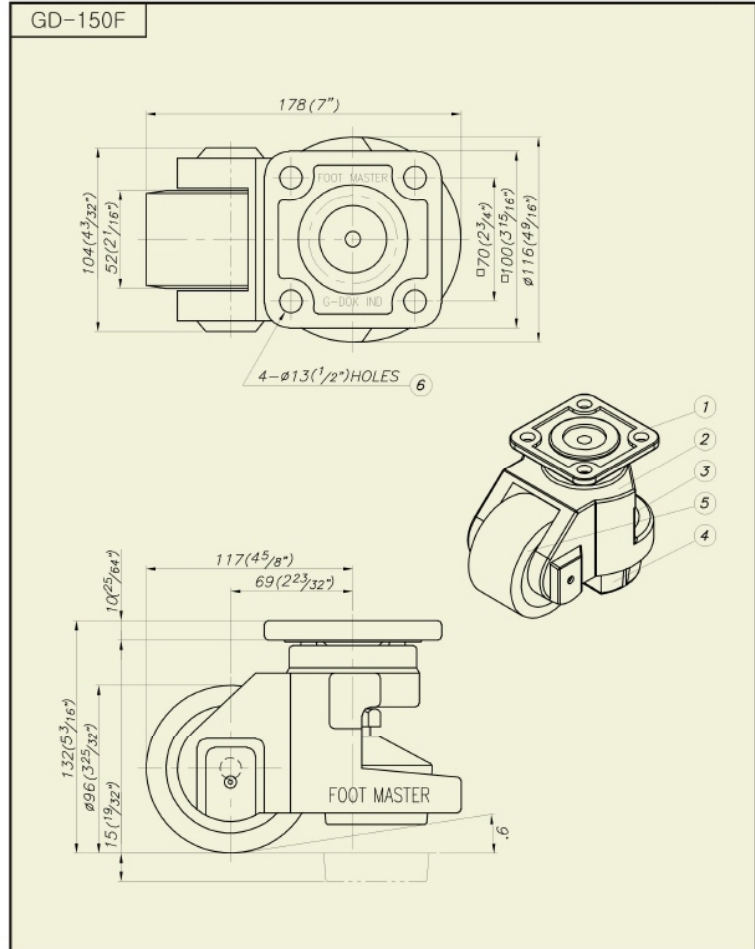

■ Specification (제원)

Load capacity/pce (개당 허용하중)	1,500 kg (3,300 lbs)	
Recommended load/4 pcs (4개당 추천하중)	3,000 kg (6,600 lbs)	
Net weight (자중)	F-type	3.5 kg (7.7 lbs)
Temperature range (사용온도)	-10 ~ +90℃ (+14 ~ +194°F)	

■ Material (재질)

① Top plate (취부판)	Forged steel	
② Frame (몸체)	Aluminum diecasted	
③ Handle (핸들)	Carbon steel	
④ Leveling pad (받침대)	Aluminum	
⑤ Wheel (바퀴)	MC nylon / B-type : MC nylon wheel with ball bearing	
⑥ Mounting bolt (취부볼트)	F-type	4-M12x1.75P
⑦ Surface treatment (표면처리)	Powder coated & Zinc galvanized	