

LEVELING CASTER 높낮이 조절용 캐스타	FOOT MASTER® GD-120	HEAVY DUTY PURPOSE 고 중하중용(高 重荷重用)
---------------------------------------	-------------------------------	---

■ Outlines (외형도)

Unit : mm (inch)



GD-120S

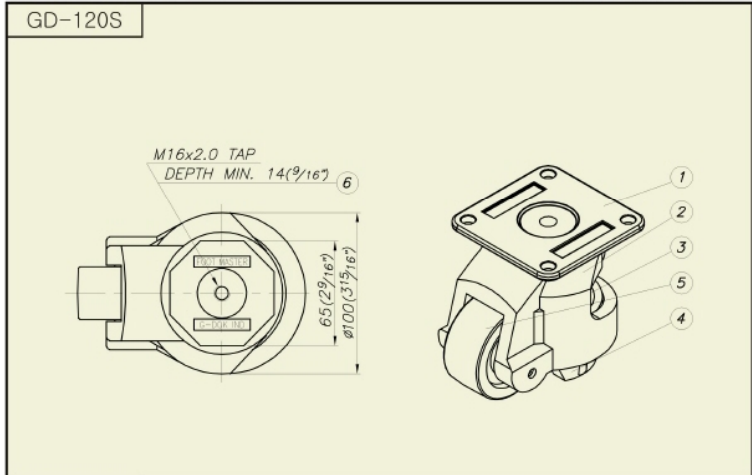

GD-120F

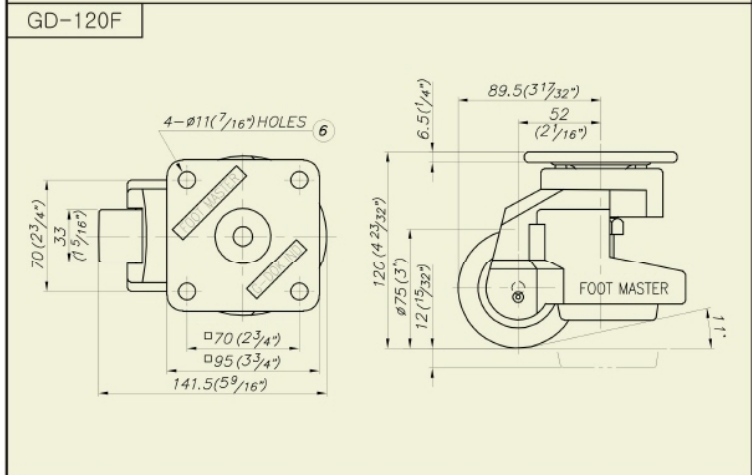

■ Specification (제원)

Load capacity/pce (개당 허용하중)	1,000 kg (2,200 lbs)	
Recommended load/4 pcs (4개당 추천하중)	2,000 kg (4,400 lbs)	
Net weight (자중)	S-type	1.9 kg (4.2 lbs)
	F-type	2.2 kg (4.9 lbs)
Temperature range (사용온도)	-10 ~ +90℃ (+14 ~ +194°F)	

■ Material (재질)

① Top plate (취부판)	F-type : Pressed steel / S-type : Forged steel	
② Frame (몸체)	Aluminum diecasted	
③ Handle (핸들)	Carbon steel	
④ Leveling pad (받침대)	ABS (Aluminum by order)	
⑤ Wheel (바퀴)	Nylon-6	
⑥ Mounting bolt (취부볼트)	S-type	M16x2.0P
	F-type	4-M10x1.5P
⑦ Surface treatment (표면처리)	Powder coated & Zinc galvanized	