

<b>LEVELING CASTER</b> 높낮이 조절용 캐스타	<b>FOOT MASTER<sup>®</sup></b> GD, GDN-40	<b>LIGHT DUTY PURPOSE</b> 경 하중용(輕 荷重用)
---------------------------------------	--	---

■ Outlines (외형도)

Unit : mm (inch)

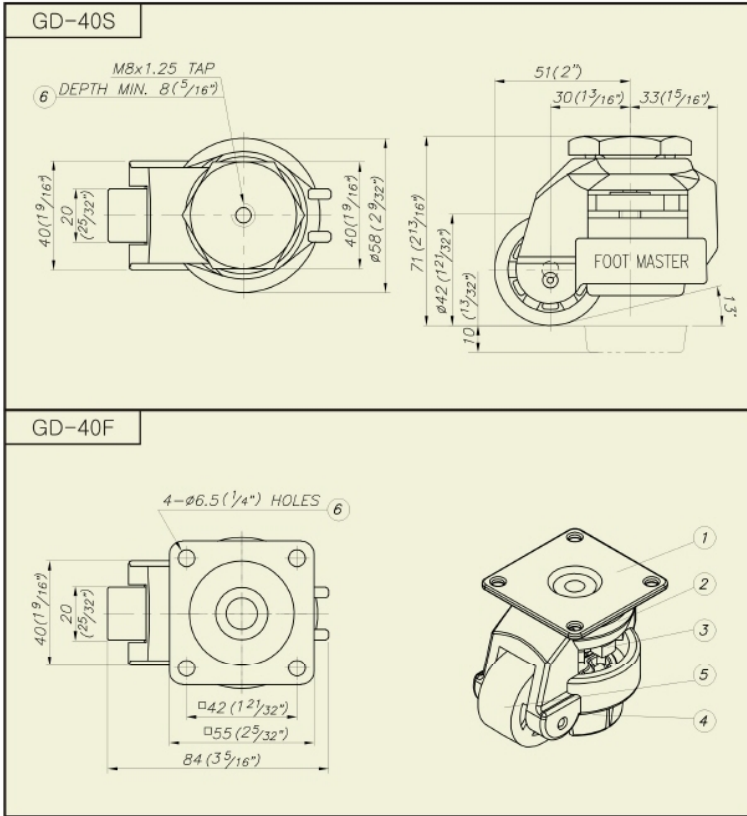

■ Specification (제원)

Load capacity/pce (개당 허용하중)	50 kg (110 lbs)	
Recommended load/4 pcs (4개당 추천하중)	100 kg (220 lbs)	
Net weight (자중)	F-type	0.4 kg (0.9 lbs)
	S-type	0.4 kg (0.9 lbs)
Temperature range (사용온도)	-10 ~ +90℃ (+14 ~ +194°F)	

■ Material (재질)

① Top plate (취부판)	F-type : Pressed steel / S-type : Forged steel	
② Frame (몸체)	Aluminum diecasted	
③ Handle (핸들)	ABS	
④ Leveling pad (받침대)	NBR (Polyurethane, Anti-static polyurethane available by order)	
⑤ Wheel (바퀴)	Nylon-6	
⑥ Mounting bolt (취부볼트)	F-type	4-M6x1.0P
	S-type	M8x1.25P
⑦ Surface treatment (표면처리)	Powder coated & Zinc galvanized	