

LEVELING CASTER
WITH RATCHET
라쳅트형 높낮이 조절용 캐스타

FOOT MASTER®
GDR-60

MEDIUM DUTY PURPOSE
중 하중용(中 荷重用)

■ Outlines (외형도)

Unit : mm (inch)



GDR-60S-U

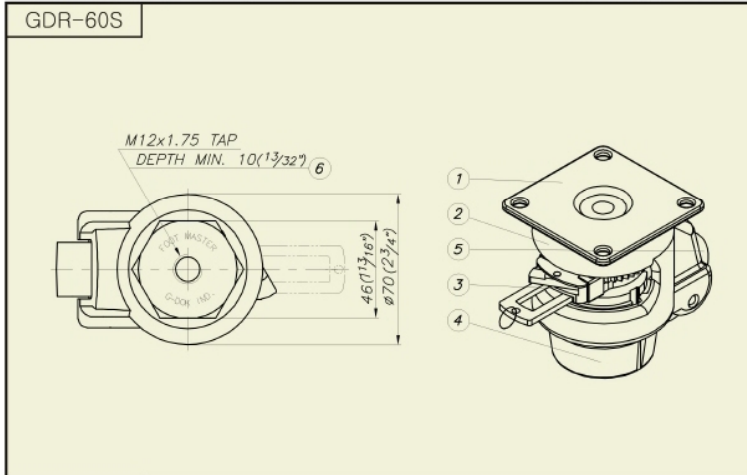

GDR-60F

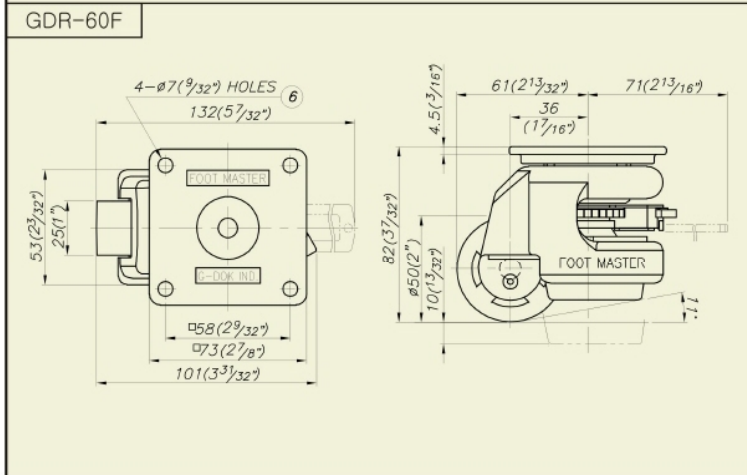

■ Specification (제원)

Load capacity/pce (개당 허용하중)	250 kg (550 lbs)	
Recommended load/4 pcs (4개당 추천하중)	500 kg (1,100 lbs)	
Net weight (자중)	S-type	0.7 kg (1.6 lbs)
	F-type	0.8 kg (1.8 lbs)
Temperature range (사용온도)	-10 ~ +90℃ (+14 ~ +194°F)	

■ Material (재질)

① Top plate (취부판)	F-type : Pressed steel / S-type : forged steel	
② Frame (몸체)	Aluminum diecasted	
③ Handle (핸들)	Ratchet tool	
④ Leveling pad (받침대)	NBR (Polyurethane, Anti-static polyurethane available by order)	
⑤ Wheel (바퀴)	Nylon-6 / U-type : Polyurethane with aluminum core	
⑥ Mounting bolt (취부볼트)	S-type	M12x1.75P
	F-type	4-M6x1.0P
⑦ Surface treatment (표면처리)	Powder coated & Zinc galvanized	